

GERMAN TEAM DISPLAY 2012 – Choreografie

Anselm Lingnau (anselm@strathspey.org) · Stand: 10.11.2011

1 Ablauf-Übersicht

Nr	Tanz	Art	Aufstellung
1	Scott Meikle	R32	4c längs
2	Barbara's Strathspey	S32	2×3c längs
3	Best Set in the Hall	J32	5c quer
4	The Bonnie Tree	S32	3c längs
5	Links w/St Petersburg	J32	3×2c im Stern
6	The Gardeners' Fantasia	S32	2×3c quer, Top innen
7	High Society	R40	4c längs
8	Peggy Spouse MBE	S32	2×3c quer, Top außen
9	The Zoologist	J32	2×3c längs nebeneinander

2 Personen-Übersicht

	Name	Scott	Barb	Best Set	Tree	Links	Gardener	High	Peggy	Zoo
A	Leif	1	2	–	–	2	1	3	2	1
B	Martin	2	2	1	1	1	3	4	3	3
C	Kevin	3	1	2	–	2	2	–	1	2
D	Norbert	4	1	5	3	1	3	1	3	3
E	Stefan	–	3	3	–	2	2	–	1	2
F	Gisela	–	3	4	2	1	1	2	2	1
A	Marie	1	2	–	–	2	1	2	2	1
B	Johanna	2	2	1	1	1	3	1	3	3
C	Ute	3	1	2	2	1	1	3	2	1
D	Daphne	4	1	5	3	1	3	4	3	3
E	Annette	–	3	3	–	2	2	–	1	2
F	Ilona	–	3	4	–	2	2	–	1	2

Die B-, C- bzw. D-Damen werden ggf. nach »Links with St Petersburg« gegen weitere Damen vom Rand ausgetauscht.

3 Choreografie

Abweichungen von den offiziellen Tanzbeschreibungen sind *kursiv gesetzt*.

3.1 Scott Meikle (R32)

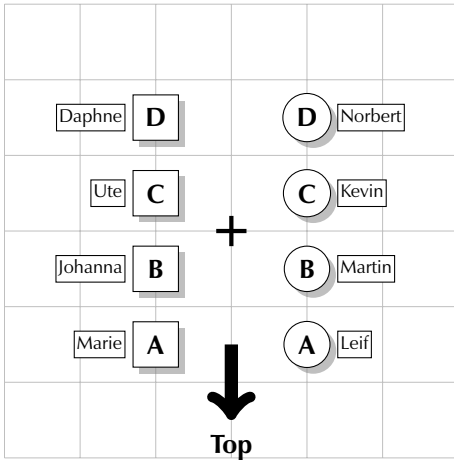

- 1–8 | 1C cross RH | cast (2C up) ; 1/2 Fig8 up (2,1,3,4)
- 9–16 | 1C+3C RHA, LHA
- 17–24 | 1W with 3W following (dance as one) with 2C and 3M (1M following)
with 4C LSh opposing Reels3 across (to 2,3,1,4)
- 25–32 | 1C+4C 1/2 R&L ; *all turn RH 1 1/2* (2,3,4,1)

Bars 29–32:

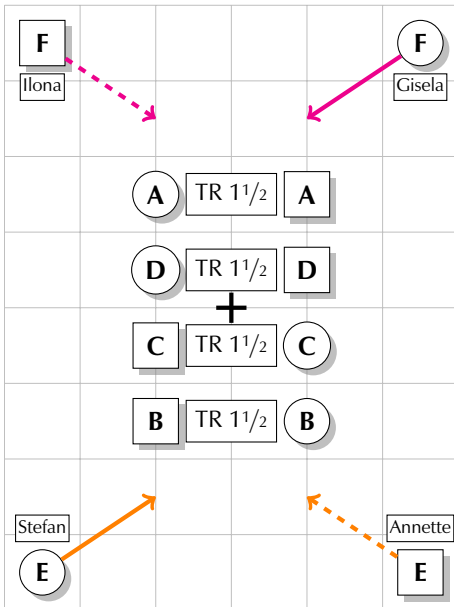

Barbara's Strathspey, bar 1:

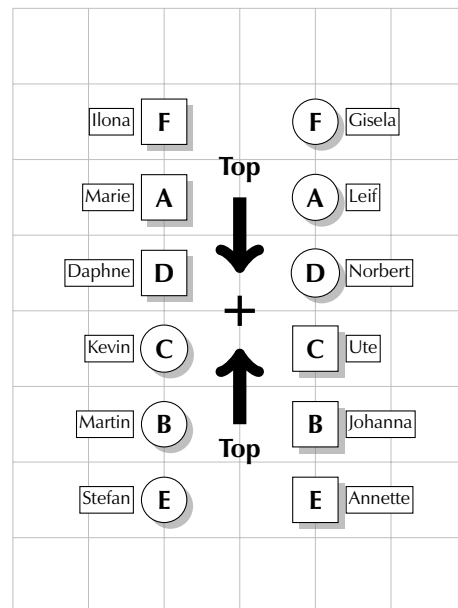

3.2 Barbara's Strathspey (S32)

- 1-4 | 1C set, cast off [2C up]
- 5-8 | 1/2 figures of eight (1M up, 1W down)
- 9-10 | 2C+1C+3C set
- 11-12 | 1C pass RS to opposite side facing out
- 13-16 | 1M+2M, 1W+3W turn R 1 1/2
- 17-24 | Three-couple Bourrel: 1M sets advancing to 3W (2M to 1W) **while** 2W and 3M chase clockwise to the ends of the set;
3C+1C+2C set to partner, turn B to sides
B, C, F, D couples face clockwise, E couple face partner, A couple face men's side
- 25-28 | *B, C, F, D couples chase clockwise one quarter into set across **while** E couple spiral round partner **while** A couple dance off*
- 29-30 | *B, C, E couples turn R 1/2 **while** D and F couples turn R*
- 31-32 | All »twirl« out to new sidelines

Bars 25-28:

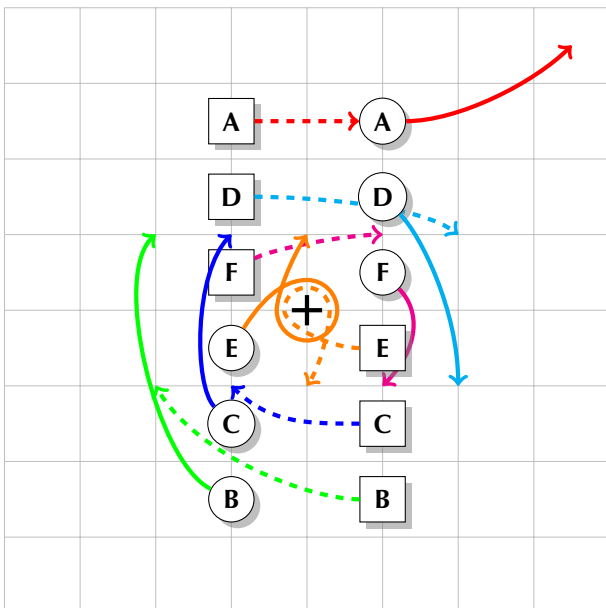

Bars 29-30:

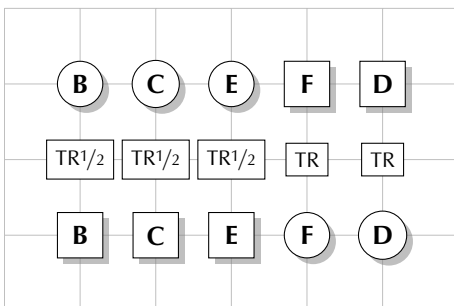

Bars 31-32:

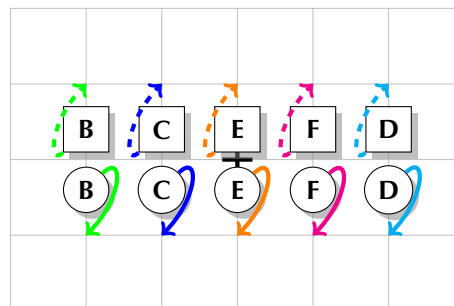

3.3 Best Set In The Hall (J32, 5-couple display version)

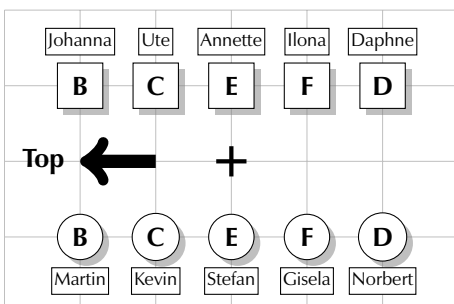

- 1–2 1C (5C) set
 3–8 1W casts off two places, dances across to the men's side, and casts up to finish facing first corner (pull LS back) **while** 1M dances across to the women's side, casts off two places, and dances up the middle to face first corner [2C up on 7–8].
At the same time, 5M dances as 1W, 5W as 1M from the other end of the set. 4C move down on 7–8.
 9–16 1C set to first corners (2M+3W), pull RS back and dance into the corner place behind them **while** corners dance in to face their original place. 1C set to first corners again, corners pull RS back and dance into the place diagonally opposite their original place **while** 1C dance in and pivot right about to face second corners.
5C dance likewise with 3M+4W.
 17–24 Repeat 9–16 with second corners (2W+3M, 2M+4M). 1C (5C) finish in second (fourth) place on opposite sides.
 25–30 *Middle three couples dance a 6-bar chase clockwise three-quarters round. End couples dance off.*
 31–32 *Middle three couples turn R 1/2 to finish in a 3-couple set at right angles to this dance.*

Bars 25–26:

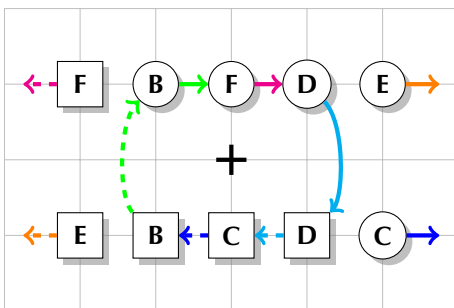

Bars 31–32:

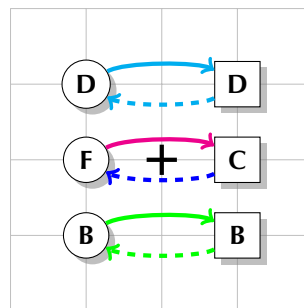

3.4 The Bonnie Tree (S32)

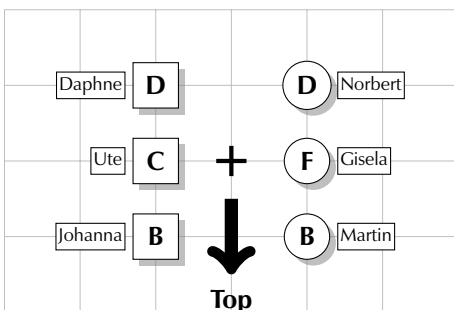

- 1–8 1C dance down below 3C, cast up, meet, dance up to the top and cast to second place [2C up on 7–8]
 9–12 2C+1C+3C 1/2 turn B and »twirk« out to opposite sides
 13–16 2C+1C+3C circle6 to L 3/4 to finish in lines across the set [men facing down, women up]
 17–18 1C change places R [face out]
 19–20 1C cast to their R [to second pl own sides] **while** 2W+3M change places R
 21–22 1C change places R [face out]
 23–24 1C cast to their R [to 1M in the middle in third place, 1W in the middle in first place] **while** 2M+3W change places R
 25–28 1C+2C+3C 1/2 turn B and »twirk« out into the opposite line of three
 29–32 *Transition into triangular arrangement of two-couple sets (see figure)*

Bars 29–32:

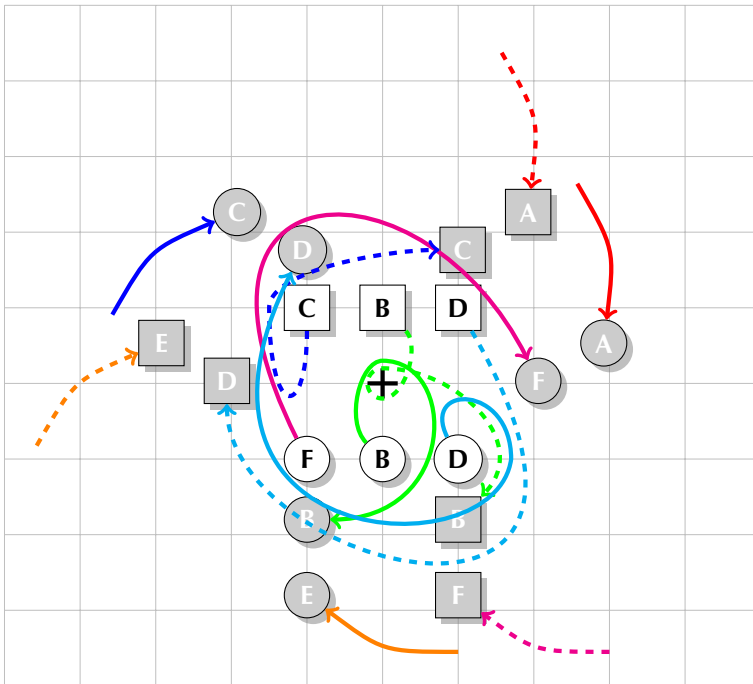

3.5 Links with St Petersburg (J32)

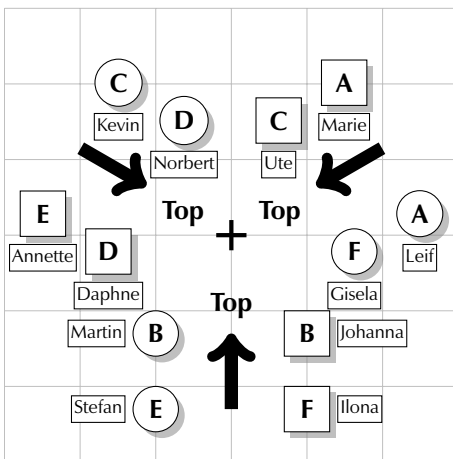

- 1–4 | 1M+2M, 1W+2W set & link, finish in lines across, NH joined w/partner, 1C facing up, 2C down
- 5–8 | 2C+1C set & link, finish on opposite sides, 2C in first, 1C in second place
- 9–16 | 1C followed by 2C dance down the middle (3 steps, NH), on 12–13, W turn under M's arms, 2C followed by 1C dance up the middle (3 steps), 2C finish facing out in first place
- 17–20 | 2M+1M turn L **while** 2W+1W turn R
- 21–24 | 2M+1M turn R **while** 2W+1W turn L
- 25–26 | All set to partners
- 27–32 | M cast, W advance into big chase clockwise to end in progressed places for next dance

Bars 27–32:

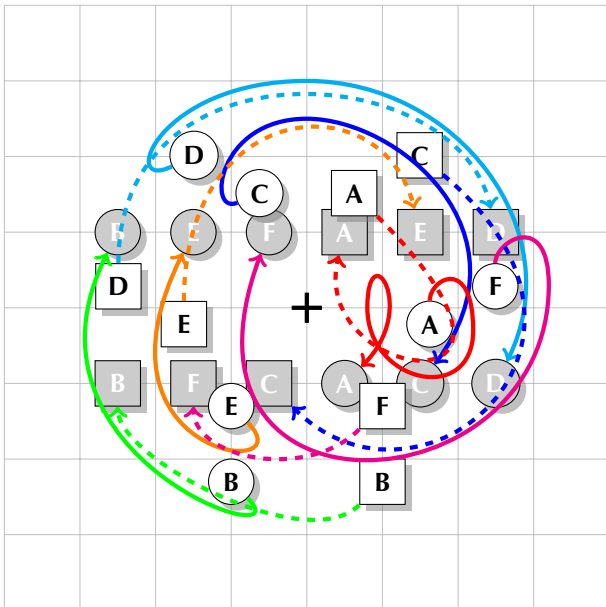

An dieser Stelle können die B-, C- bzw. D-Damen ausgewechselt werden.

3.6 The Gardeners' Fantasia (S32)

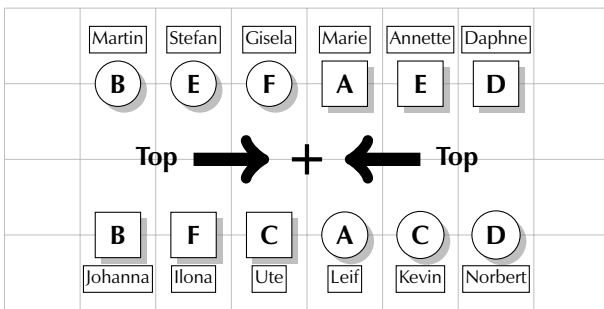

- 1–4 1C+2C circle4 to L to finish 1C facing down, 2C up, NH joined
- 5–8 1C+2C set, 1C turn towards each other and cast **while** 2C dance up [1C face 3C who have stepped in]
- 9–16 1C+3C dance a rondel [3C finish facing first corner positions] **while** 2Cs from both sets dance a rondel (see fig.); after the third arch all 2s need to cross over
- 17–24 3C set to and turn corners to finish in second place opp sides
- 25–28 3C dance up through first place and cast off one place **while** 2C+1C change places R on sides, then 1C change places L across **while** 2C turn L and keep hands
- 29–32 2C dance off **while** 3C change places R and curve to join the new set at the ends **while** 1C turn B with the corresponding person from the other set (new partner for the next dance)

Bar 9:

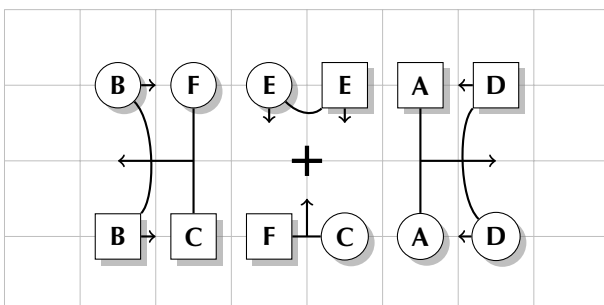

Bars 29–32:

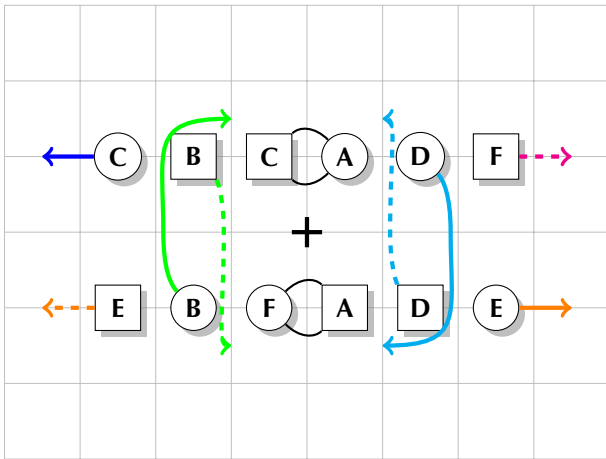

3.7 High Society (R40)

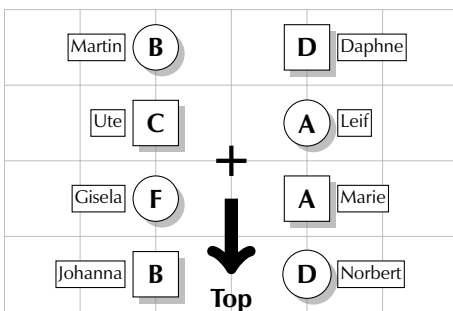

- 1–8 Reels4 on sidelines – on 8, 2C+3C do not pass but pull RS back
- 9–16 1C+3C, 2C+4C dance rights & lefts beginning on sides
- 17–24 3C+2C poussette (3C dancing towards men's side, 2C towards women's)
- 25–28 2C dance 1/2 fig 8 round 1C (3C round 4C) [1,2,3x,4x]
- 29–32 All turn R to finish in the middle, 1C+2C facing up, 3C+4C facing down
- 33–40 »Allemande« round in a loop for 6 bars. Dance towards the other two couples and, on 39–40, cross over to other side

Bars 33–38:

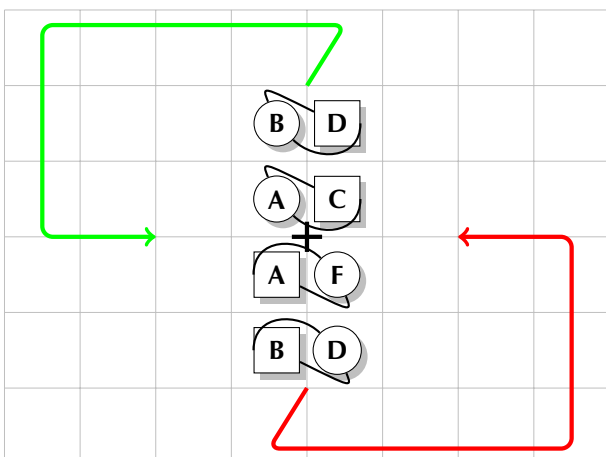

Bars 39–40:

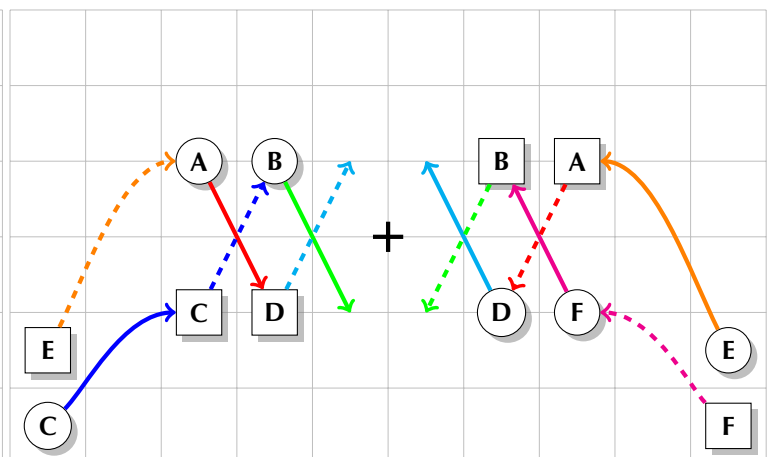

3.8 Peggy Spouse MBE (S32)

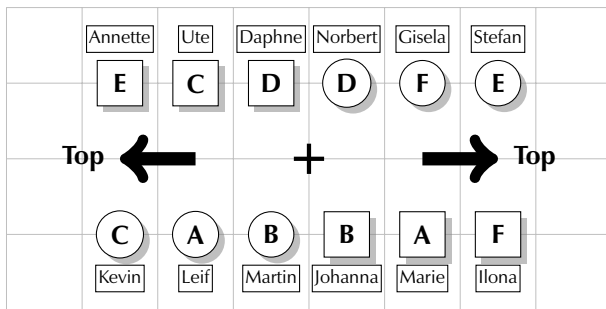

- 1–4 1W+2M cross (passing LS), dance round partners by RS to finish facing partners ready for ...
- 5–8 1C+2C 1/2 poussette
- 9–14 1W+2C, 1M+3C reels3 across (1W+2M, 1M+3C pass LS to begin)
- 15–16 1W dances up and pulls RS back to finish in first place in the middle facing down **while** 1M dances down and pulls RS back to finish in third place in the middle facing up **while** 2C+3C curve in to meet partners w/NH joined, 2C facing 1W, 3C facing 1M
- 17–20 1C+2C+3C set, 1W+2C, 1M+3C 1/2 circle3 (1C finish back to back)
- 21–24 1C set & petronella to second place own sides **while** 2C+3C set & link to own sides
- 25–28 »Left« (C man) set 1/2 circle6 to L **while** »right« (E man) set 3/4 circle6 to L
- 29–32 »Left« set 3/4 circle6 to R **while** »right« set 1/2 circle6 to R

3.9 The Zoologist (J32)

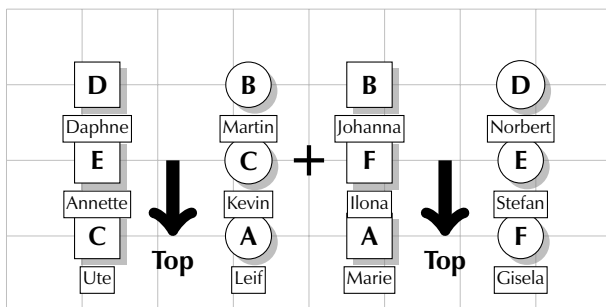

- 1–4 1C cross down R, dance out between 2C+3C; 1W casts up to between 2C facing 2W **while** 1M casts off to between 3C facing 3M [2C up on 1–2]
- 5–8 1W+2C, 1M+3C 1/2 reels3 across [1W+2W, 1M+3M pass L to begin, 1C finish facing first corner positions]
- 9–12 2W+1C+3M 1/2 reel4 on diagonal [1C pass R on 12 to face second corner positions]
- 13–16 2M+1C+3W 1/2 reel4 on diagonal [1C pull RS back on 16 ready for ...]
- 17–24 Double triangles [1C pull RS back on 23–24 to finish RS to RS facing opposite sides]
- 25–28 1M+3C, 1W+2C LH across [1C finish RS to RS again]
- 29–32 »Snake movement«: 1M+3M+3W dance down the W's side, across in third place, up to second place own side (3C finish in original places) **while** 1W+2W+2M dance up the M's side, across at top, down to second place own side (2C finish in first place)
- 33–36 Both sets 1/2 chase clockwise into big circle
- 37–40 Big circle to L; pivot R at end and bow/curtsey to audience