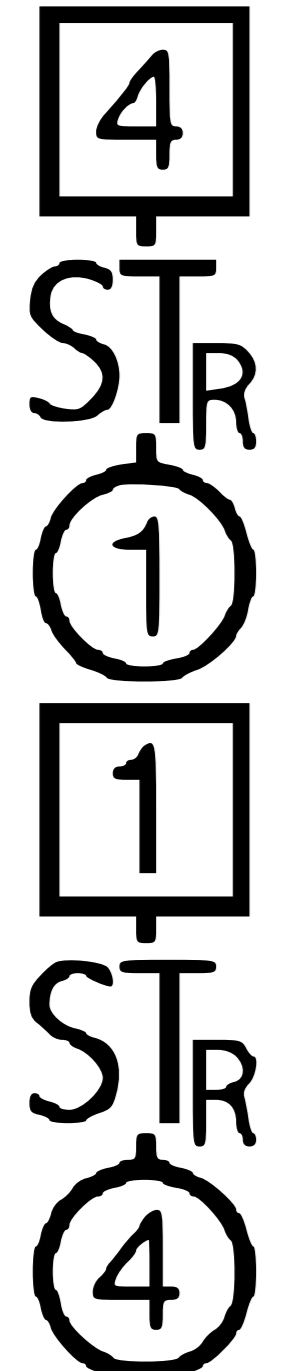
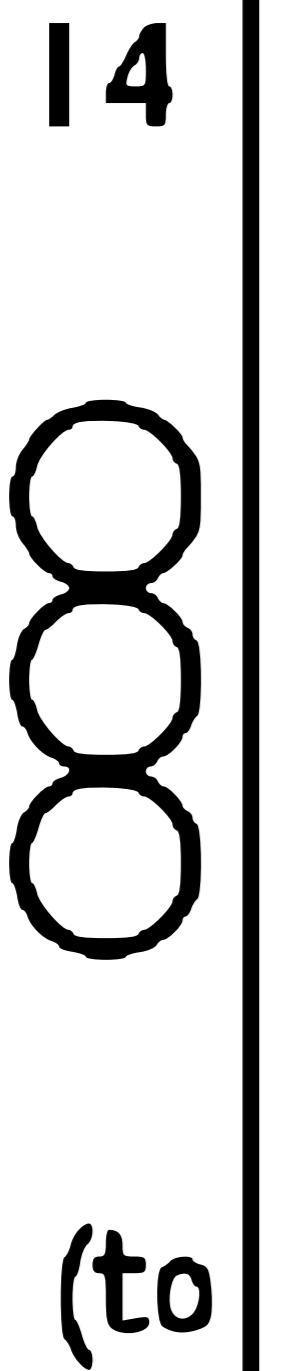
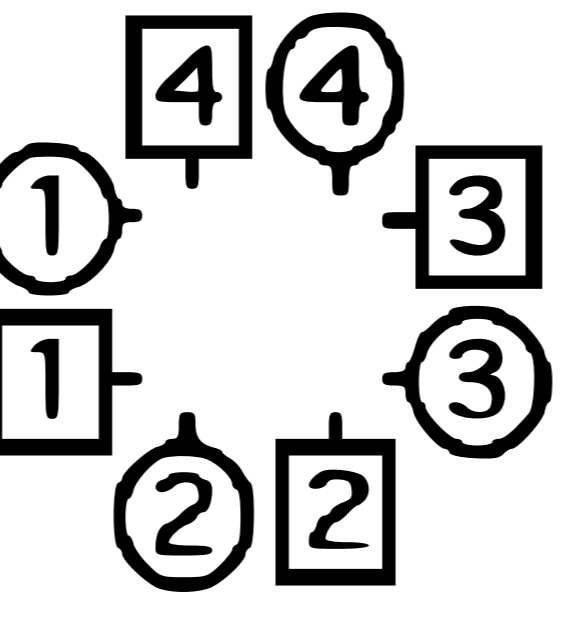

# LAMONT OF INVERYNE

MacNab I 6

R208

3 (X) RH  
 (to)  14  
 (to)  4  
 3 (X) RH  
 to places

ALL  
 S<sub>2</sub>T<sub>B</sub>  
 to   
 WOMEN  
 RA<sub>1 1/4</sub>  
 (dance on one place)  
 ALL  
 S<sub>T</sub>L  
 with new partner

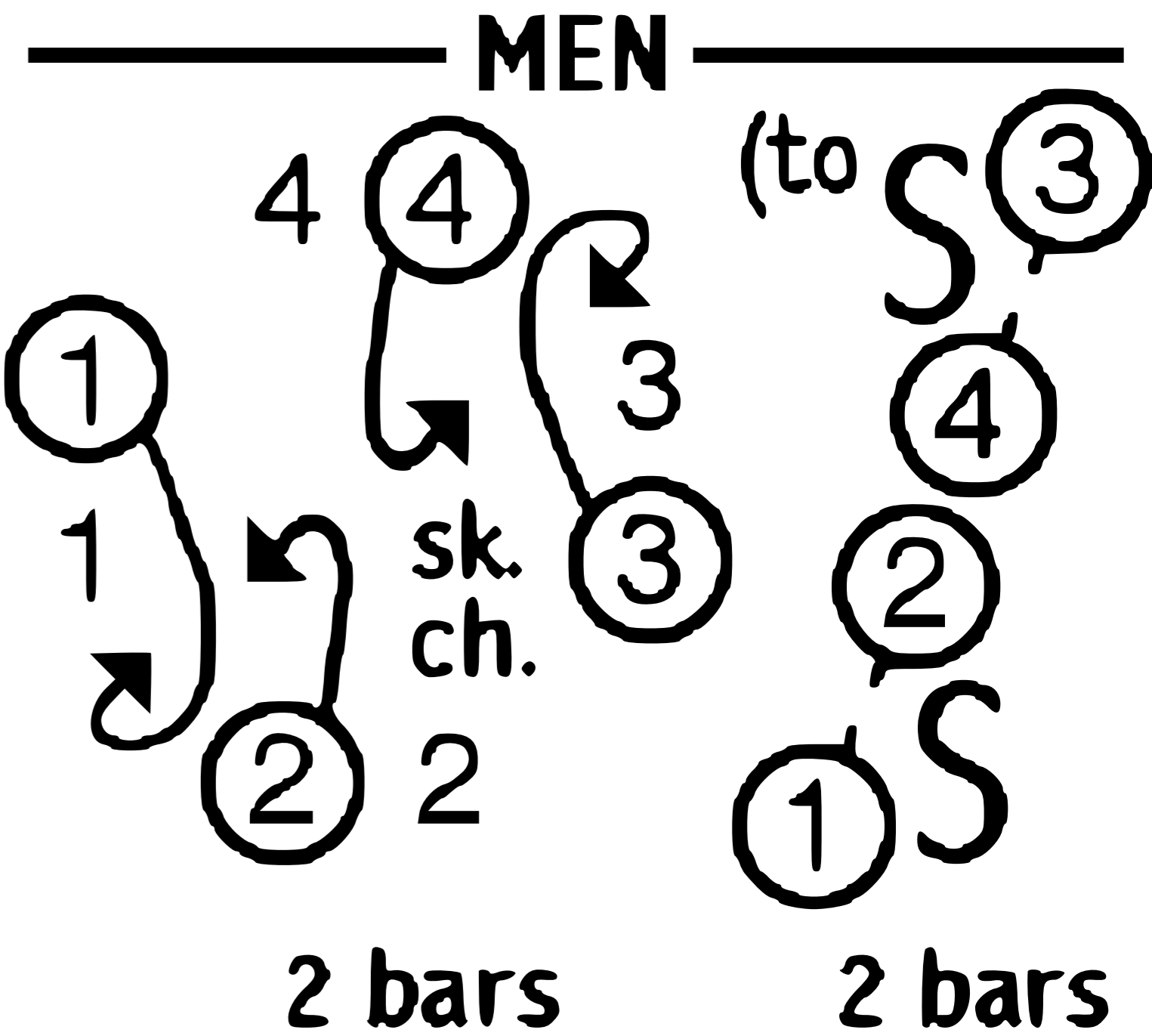
MEN  
  
 2 bars

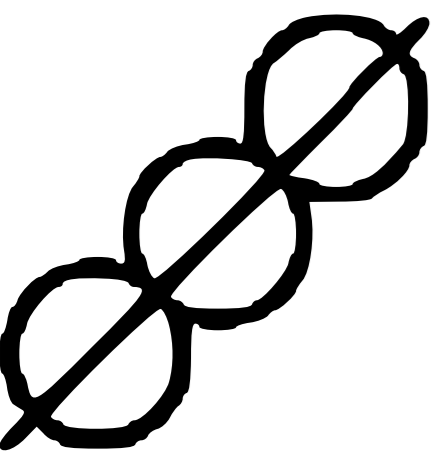
MEN  
  
 mendance by left into opp. woman's place, pulling L sh back on last 2 bars as  
 woman dances into middle passing L sh to face him

ALL  
 R  
 1-16 on other diag. M1, M3 turning by L to begin reel (to places)

ALL  
 S<sub>2</sub>T<sub>B</sub><sup>1/2</sup>S<sub>↓</sub>  
 to original lines

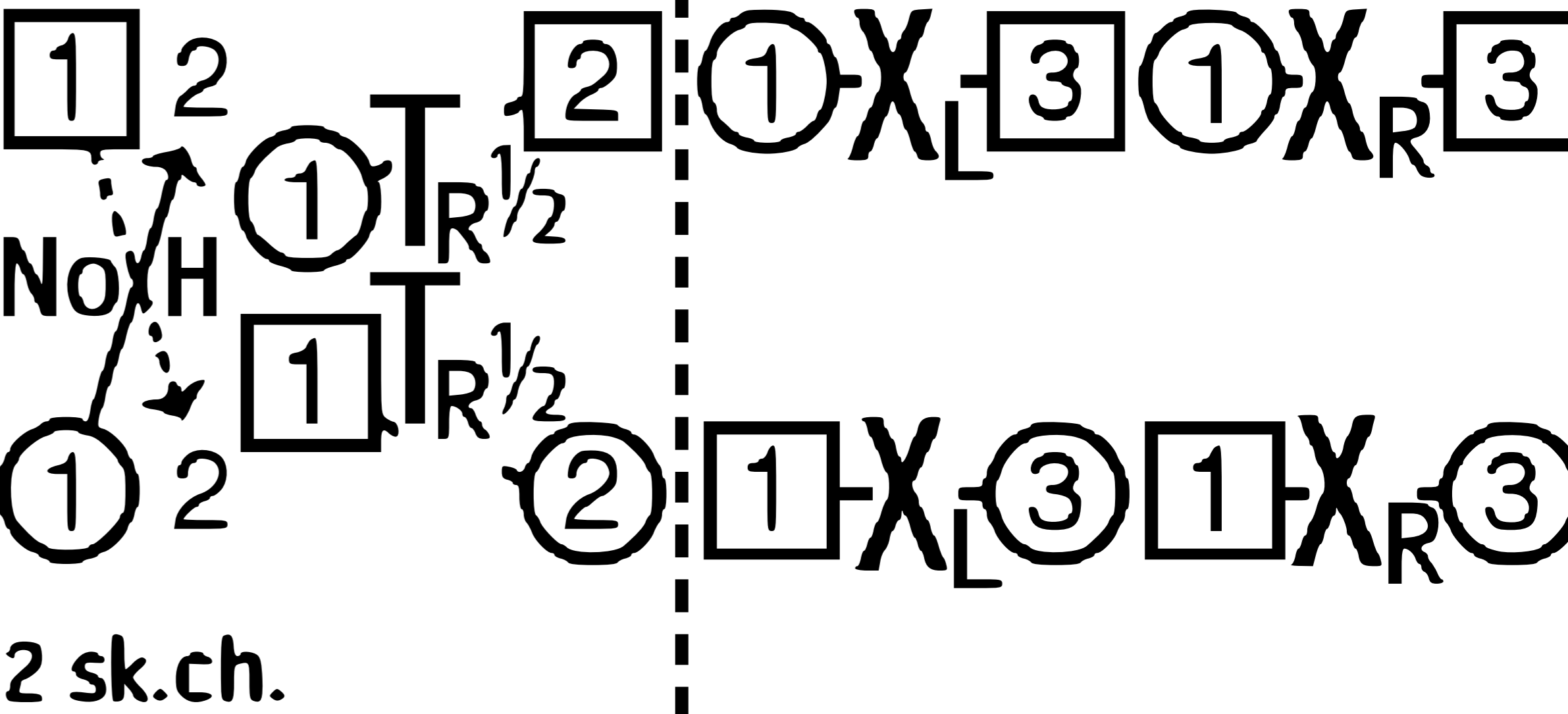
  
 2 sk. ch.

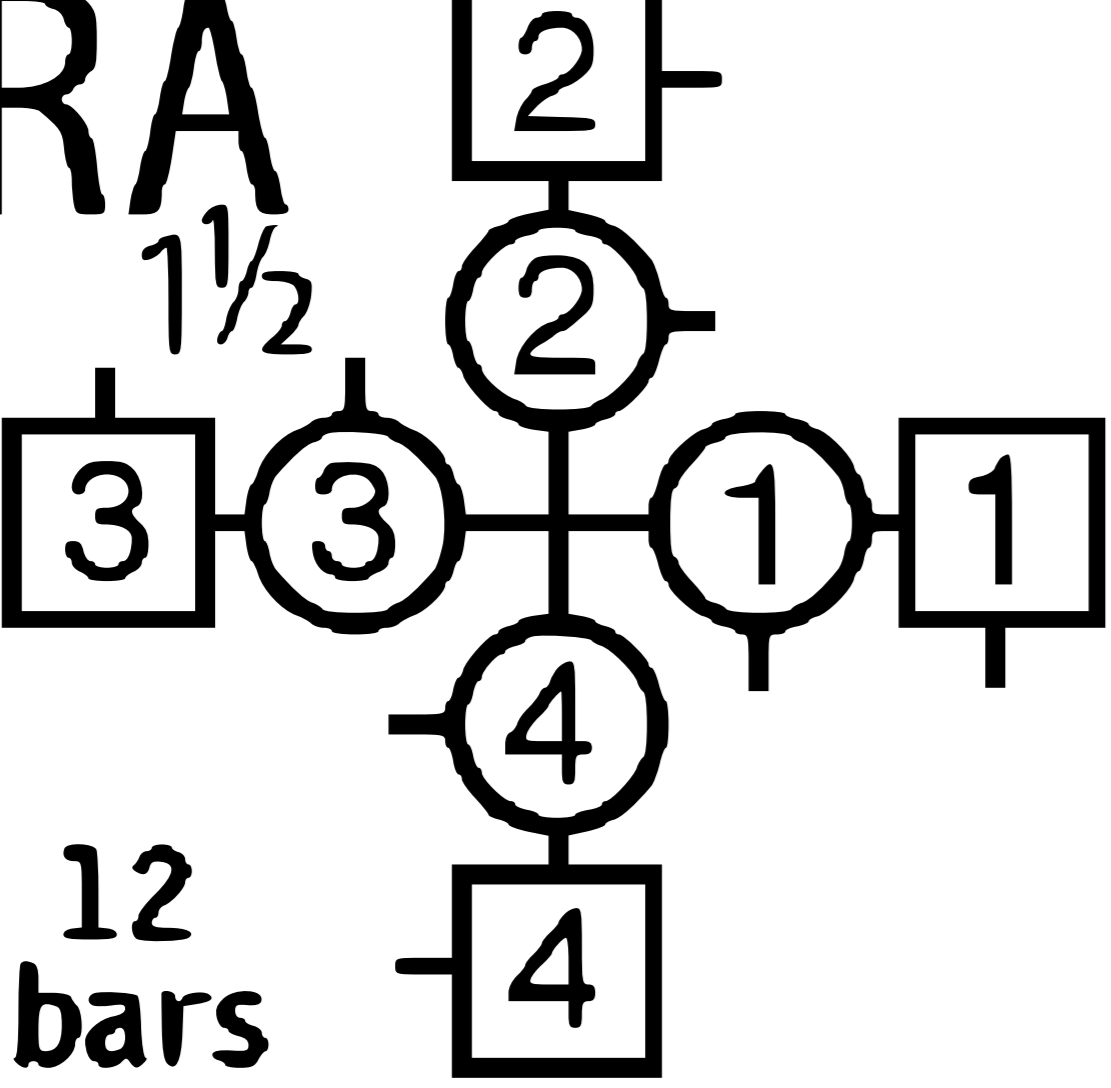
ALL  
 S<sub>2</sub>T<sub>L</sub>  
 (to)   
 12 bars

MEN  
 RA  
 (retain hands)  
 4 bars

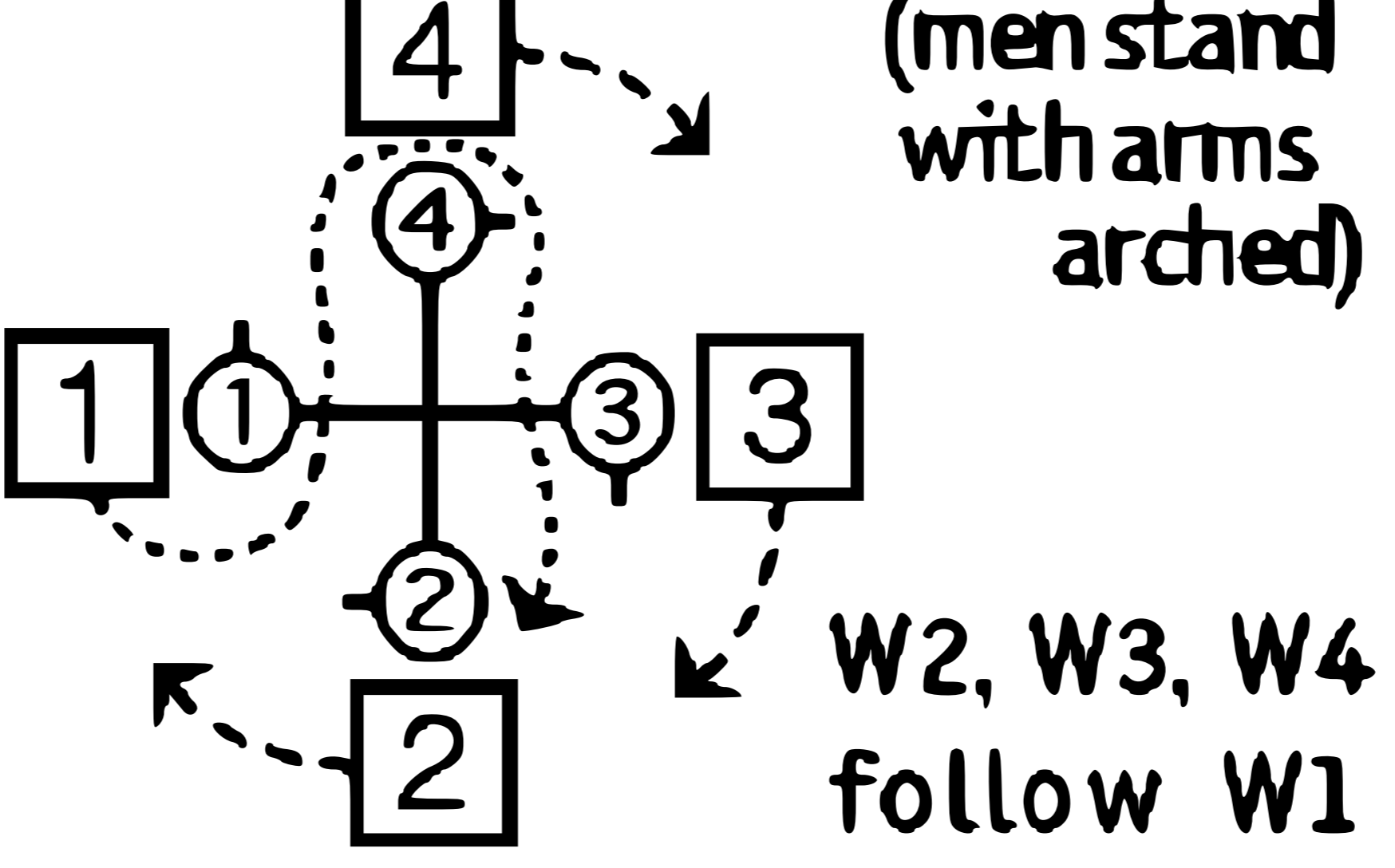
  
 (men stand with arms arched)  
 W2, W3, W4 follow W1

WOMEN  
 reverse to starting places bar 9  
 (MEN quick change to LH)

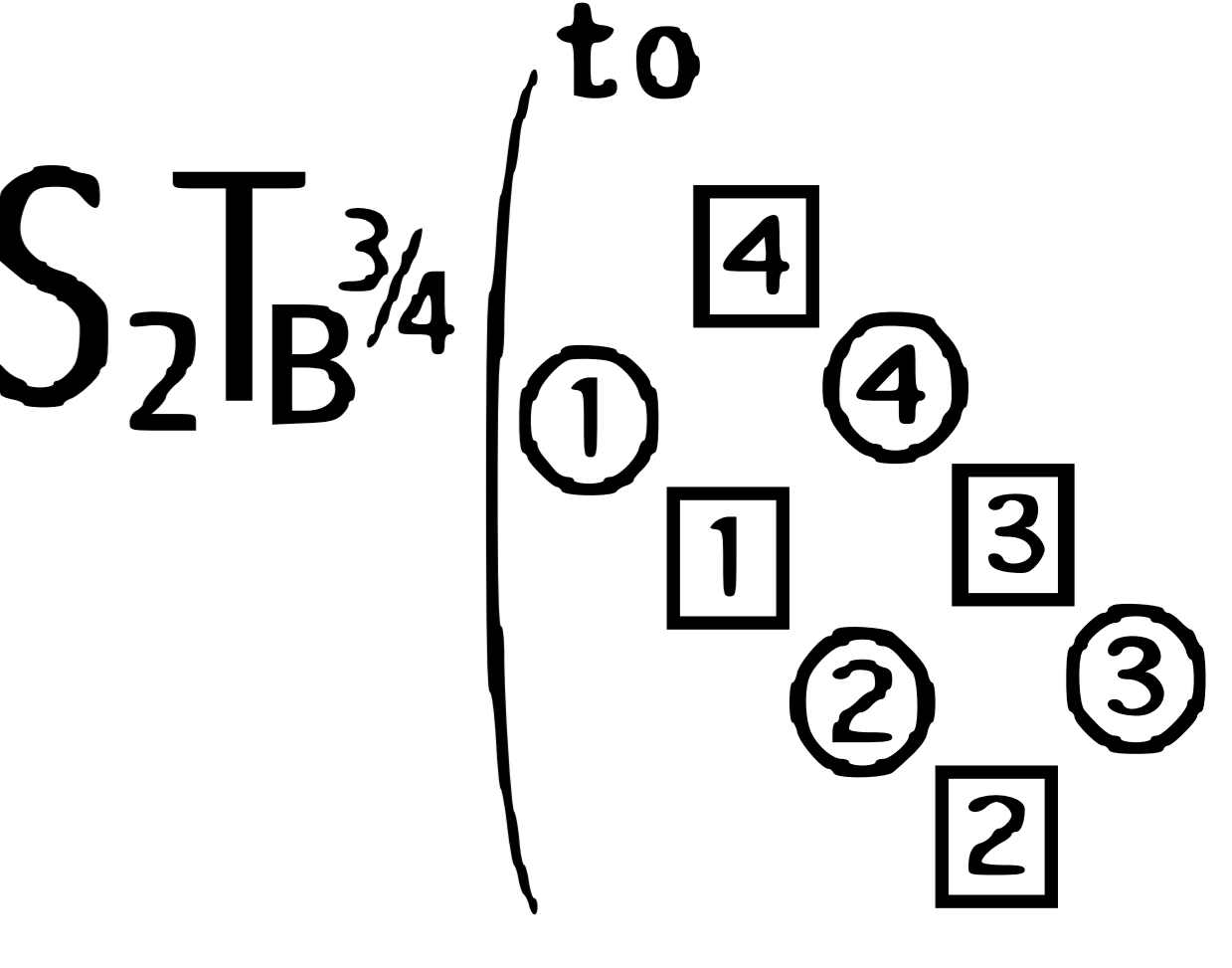
ALL  
 S<sub>2</sub>T<sub>B</sub><sup>3/4</sup>  
 to 

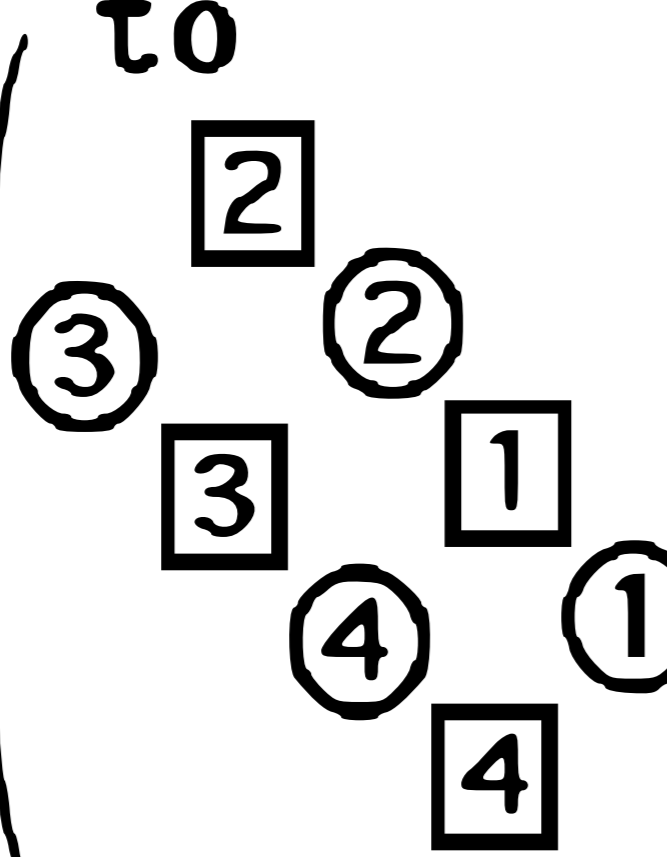
W1M4, W3M2 | W4M1, W2M3  
 R<sub>L</sub> inside 4 p.d.b. (to face partner)  
 R<sub>L</sub> outside 4 sk. ch. per hand  
 to 

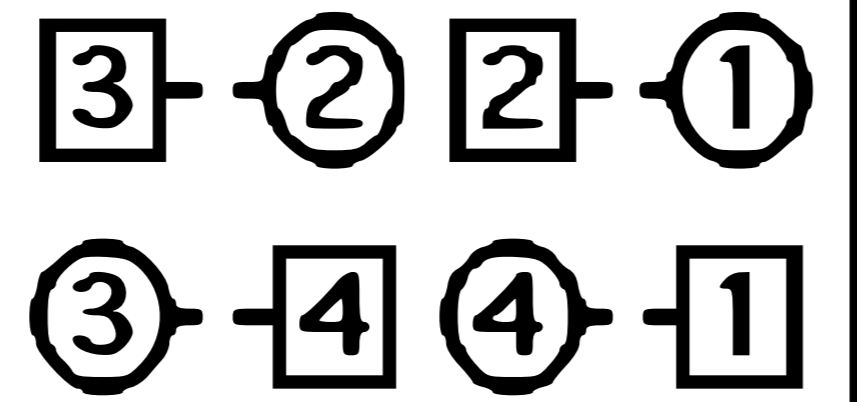
ALL  
 S<sub>2</sub>T<sub>B</sub><sup>2/3</sup>  
 (to) 

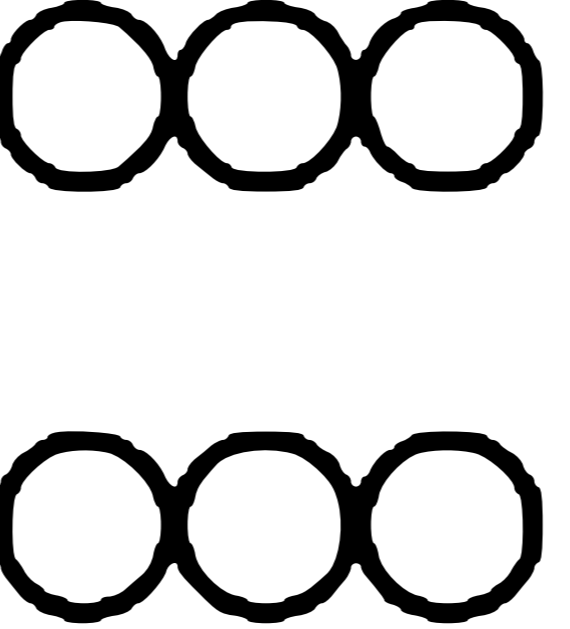

ALL  
 CHAIN  
 16 bars  
 (Start: RH to partner)

ALL  
 P  
 progressing & turning to 1,2,3,4  
 1C: 0 1/4 | S | 1/2 | S | 1/4 | I | 1/2 | 0  
 2C: 1/2 | S | 1/4 | C | 1/4 | S | 1/4 | I | 1/2 | 0  
 3C: 0 | 1/4 | S | S | 1/4 | I | 1/2 | 0  
 4C: S | 1/4 | C | 1/4 | 1/4 | I | 1/2 | 0

KEY:  
 C=cross  
 I=in  
 O=out  
 S=along side  
 1/4=turn  
 1/2=turn